

GATOR UTILITY VEHICLES



CONTENTS

WORK UTILITY VEHICLES

Need a versatile workhorse with easy loading and good ride quality? Our Work Utility Vehicles come with petrol, diesel or electric power, four wheels or six and a host of features that make life easier.

06



CROSS-OVER VEHICLES

26



XUV 590i



XUV 560



XUV 855D S4



XUV 590i S4



XUV 855D



XUV 825i



WORK UTILITY VEHICLES

10



T-Series



HPX



ProGator

Dealer Support 4–5

WORK UTILITY VEHICLES

Outstanding Features 8–9

Gator TS 10–11

Gator TX & TX Turf 12–13

Gator TE 14–15

Gator TH 6x4 16–17

Gator HPX 18–19

ProGator 20–21

CROSS-OVER VEHICLES

Outstanding Features 24–25

Gator XUV 560 26–27

Gator XUV 590i 28–29

Gator XUV 590i S4 30–31

Gator XUV 855D 32–33

Gator XUV 855D S4 34–35

Gator XUV 825i 36–37

ATTACHMENTS 38–51

PRODUCT SPECIFICATIONS 52–55



22

CROSS-OVER VEHICLES

Despite all their speed and handling, our sure-footed XUV Gators are out-and-out commercial vehicles that thrive on hard work in tough terrain.



24

OUTSTANDING FEATURES

From hydro-formed frames to fully independent suspension, true on-demand 4WD and power steering, these intelligent features make a real difference to the way you work.

DEALER SUPPORT

WITH YOU ALL THE WAY

John Deere dealers are proud of their reputation – and rightly so. From pre-sales advice to parts, servicing and repairs, they go the extra mile to deliver the best possible solutions for your needs. Your local dealer knows all our machines inside out and will be happy to help you find the ones that suit your needs and budget best. Why not drop in for a chat?

To find your nearest John Deere dealer, visit dealerlocator.deere.com





SERVICE

The people at your local John Deere dealership are always there for you – with personal service you can rely on. As part of the John Deere community, they combine their own individual style with all the benefits of a strong global company.

REPAIRS

Even a John Deere machine needs repairs eventually. When that day comes, your dealership service centre has all the tools to diagnose the issue quickly, order what you need, and get you back up and running in no time.

ONLINE ORDERS*

Order parts anytime, anywhere from your smartphone or tablet with the mobile version of JDParts.Deere.com. Search by model number, part number or keyword to quickly find what you need – then order safely and securely at the touch of a button.

FINANCING SOLUTIONS*

As the only manufacturer with its own financial services department, we can make the numbers work for you by improving your cash flow and optimising your total cost of ownership. Benefits include flexible leasing deals and payment options, competitive rates, and a fast, easy application process that keeps red tape and jargon to a minimum.

MEET YOUR MACHINE

Your John Deere dealer doesn't just help you choose the right machine, he also walks you through the features and controls until you feel at home. And if you forget anything, competent advice is just a phone call away.

PLANNED MAINTENANCE

Keep your machine running like new with a maintenance plan that is tailored to your exact requirements. From standard servicing and scheduled parts replacement to genuine filters, lubricants and coolants, your John Deere dealer has everything you need.

WORK UTILITY VEHICLES

EXPERIENCE THE VERSATILITY



Looking for a versatile workhorse with easy loading and good ride quality? Our Work Utility Vehicles come with petrol, diesel or electric power, four wheels or six and a host of features designed to make your job easy and enjoyable all day long.



OUTSTANDING FEATURES

WORK UTILITY VEHICLES

Whichever model you choose, intuitive controls and high flotation tyres are standard.





HIGH FLOTATION TYRES

All T-Series Gator Utility Vehicles come with top quality high flotation tyres that let you work hard without damaging the turf. With their special tread pattern, they're equally suitable on hard or soft surfaces.



BRAKES

Every brake system is precisely matched to the vehicle load capacity. If you start with it in the back you can stop with it in the back.



INTUITIVE CONTROLS

Even if you've never driven a Gator before, you'll feel at home right away. All the controls are simple, clear ... and exactly where you need them.



GATOR TS

EXPERIENCE THE CAPACITY

Let the Gator TS Utility Vehicle take the strain – powered by a 401 cc petrol engine and yet it has a surprisingly light footprint on your turf (only 7.5psi – less than a human footprint). But that's not all. With its exceptional stability, intuitive operation and rugged steel, tilting cargo box, the Gator TS delivers the ultimate in versatility!



TS

Petrol Engine
Displacement: 401 cc
Speed: 32 km/h
Rear Suspension: Two High-Flotation Tyres, Low Pressure Tyres (Solid Axle)
Towing Capacity: 408 kg
Cargo Capacity: 227 kg

- Comfortable Low Load Height
- Low Centre of Gravity
- Road Homologation (Optional)*

*Homologation type may vary by country.
Please refer to you dealer.



LOW LOAD HEIGHT

With a load height of just 63.5 cm, it's easy to make full use of the 227 kg cargo capacity.

RIDE IN STYLE

The smooth engine and intuitive controls make driving a pleasure.



GATOR TX & TX TURF

EXPERIENCE THE PEACE AND QUIET

Gently does it: our whisper-quiet Gator TX models tread softly, yet they have all the power and capacity you need to get the job done quickly yet safely. Both models have high flotation turf tyres and a payload capacity of 454 kg. The TX has a powerful 675 cc engine, while the TX Turf has 401 cc – plus a foot pedal start that's so practical, you'll wonder how you managed without it.





FLAT BED

Cargo box sides can be removed in minutes to convert the box to a flat bed.

ON ALL TX & TX TURF MODELS

- Rear Suspension: Semi-Independent Coil-Over-Shock
- Towing Capacity: 454 kg
- Cargo Capacity: 272 kg
- Low Centre of Gravity
- Deluxe Cargo Box
- All-Wheel Disc Brakes
- Road Homologation (Optional)*

*Homologation type may vary by country. Please refer to you dealer.



TAILGATE

Pick-up style tailgate folds out to 90 degrees and down a full 150 degrees. The latch can be operated with just one hand.



TX

Petrol Engine
Displacement: 675 cc
Speed: 32 km/h

TX TURF

Petrol Engine
Displacement: 401 cc
Speed: 25 km/h

- Foot Pedal Start

CARGO BOX SIDE EXTENSION

Carry twice the amount of clippings and mulch by increasing cargo box side height and volume. Tailgate pivots at the top for dumping loose material.

GATOR TE

EXPERIENCE ZERO EMISSIONS

Golf courses, work premises, enclosed spaces ... When quiet operation and zero emissions are the order of the day, the Gator TE really delivers. And thanks to impressive features like powerful batteries, rapid torque rise and a multi-functional Deluxe Cargo Box, you can go electric without compromising on power or functionality.





TE

Electric Engine
Speed: 24 km/h
Rear Suspension: Two High-Flotation Tyres, Low Pressure Tyres (Solid Axle)
Towing Capacity: 273 kg
Cargo Capacity: 227 kg

- Super-Quiet Electric Operation
- Zero Emissions
- Road Homologation (Optional)*

*Homologation type may vary by country.
Please refer to your dealer.



WHISPER-QUIET ELECTRIC POWER

Thanks to eight high capacity batteries, the Gator TE can work hard for 7–8 hours between charges – all with zero emissions and practically no noise. Every unit comes with a built-in, UL approved charger that automatically shuts off after reaching full charge.

HARD WORKER

Don't be deceived by the quiet exterior of the Gator TE Utility Vehicle. With solid, one-piece forged axles, a cast aluminium rear axle housing and a Deluxe Cargo Box, it's built for hard work in all conditions.



GATOR TH 6X4

EXPERIENCE THE MUSCLE

With six wheels, a low centre of gravity and power to spare, the Gator TH 6x4 Utility Vehicle makes light work of heavy loads. Our strongest workhorse transports an impressive 726 kg (including passengers) with ease and the low load height is really easy on your back.





FULL POWER AHEAD

The powerful yet economical diesel engine makes the Gator TH 6x4 a speedy mover even when the going gets tough.

TH 6x4

Diesel Engine
Displacement: 854 cc
Speed: 32 km/h
4-Wheel Drive
Rear Suspension: Two High-Flotation Tyres, Low Pressure Tyres (Solid Axle)
Towing Capacity: 726 kg
Cargo Capacity: 544 kg

- Low Load Height
- Road Homologation (Optional)*

*Homologation type may vary by country.
Please refer to your dealer.



GOLF PRO

With six high-flotation wheels, the Gator TH 6x4 travels lightly over your valuable turf.



HEAVYWEIGHT CHAMPION

With a cargo capacity of 544 kg, the Gator TH 6x4 is the strongest workhorse in the T-Series family.

GATOR HPX

EXPERIENCE THE STRENGTH

Love challenges? So does the Gator HPX Work Utility Vehicle. It has a massive 635 kg payload capacity, plus 4-wheel drive and semi-independent suspension to help you go where others can't. Even when fully loaded, ground clearance is good – and so is stability, thanks to the hydro-formed frame. To round things off, the powerful diesel engine enables speeds of up to 40 km/h.





SAFETY FIRST

Your safety is a top priority at all times. That’s why the Gator HPX Utility Vehicle is fitted with a ROPS (Roll Over Protection Structure) canopy and comfortable automotive style 3-point seat belts as standard.

HPX

Diesel Engine
Displacement: 854 cc
Speed: 40 km/h
4-Wheel Drive
Rear Suspension: Coil-Over-Shock
Towing Capacity: 590 kg
Cargo Capacity: 454 kg

- 1** – High-Strength Hydro-Formed Steel Frame
- Standard Deluxe ROPS Canopy
- Road Homologation (Optional)*

*Homologation type may vary by country. Please refer to your dealer.

PILE IT ON

Heavy loads?
No problem, thanks
to a cargo capacity
of 454 kg.

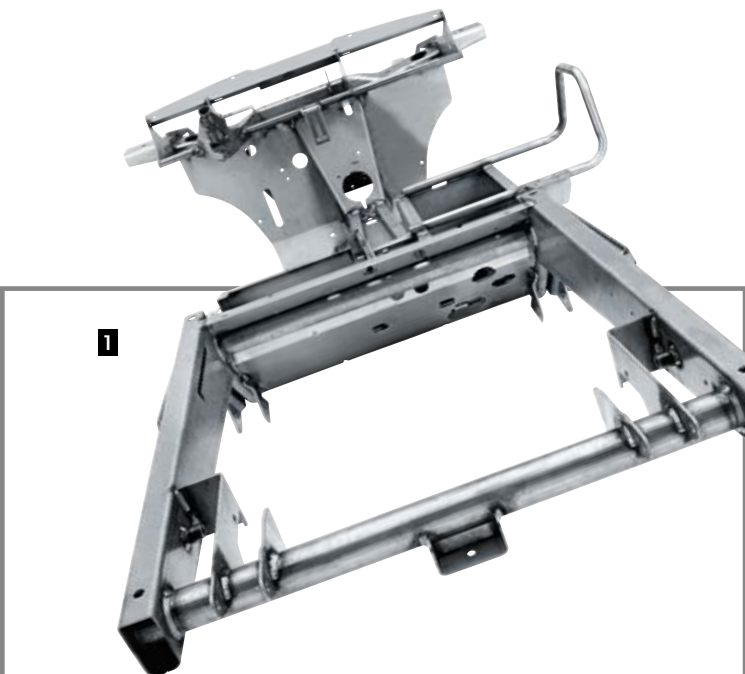

HIGH-STRENGTH HYDRO-FORMED STEEL FRAME

Our hydro-formed frames have fewer welded or bolted joints for maximum durability, plus high tolerances for twisting and heavy loads.



STOP ON A SIXPENCE

Fully hydraulic brakes ensure first-class braking performance.

PROGATOR

EXPERIENCE THE ATTITUDE

Meet our club professional! From spraying and top dressing to debris collection, the ProGator utility vehicle helps you keep your turf in peak condition. Even with the maximum payload of 1535 kg, the power steering and tight turning radius make it a pleasure to drive.



A MASTER OF ITS CRAFT

The TC125 turf collection system helps you pick up the pace when collecting aeration cores, sand, grass clippings and leaves.

GOOD TOP DRESSING IS HALF THE BATTLE

The TD100 Top Dresser features a seamless conveyor belt up to 538 litre capacity. What's more, the hopper is made of galvanised steel.



ProGator

Diesel Engine
Displacement: 1115 cc
Speed: 31 km/h
4-Wheel Drive, Optional
Rear Suspension: Dual Leaf Springs and Shocks
Towing Capacity: 680 kg
Cargo Capacity: 907 kg

- Tight Turning Radius
- Low Centre of Gravity
- 5-Speed Synchronesh Transmission
- Road Homologation (Optional)*

*Homologation type may vary by country.
Please refer to your dealer.



LET THE WATER FLOW!

That's no problem with the 750 litre capacity of the HD200 sprayer. And with a range of booms measuring 4.6 m, 5.5 m and 6.4 m, there's no shortage of choice, either!

CROSS-OVER VEHICLES

EXPERIENCE THE EXCITEMENT



When your work involves moving people and cargo across rough terrain in all weather, consider a Gator XUV Utility Vehicle. These sure-footed workhorses combine exhilarating performance with all the pulling power and versatility you demand from a hard-working professional vehicle.



OUTSTANDING FEATURES

CROSS-OVER VEHICLES

With their advanced engineering and impressive specs, our hard-working XUV Cross-Over Vehicles are the perfect balance of versatility and performance. Here are just a few of the intelligent features designed to help you work in safety and comfort all day long.



DIGITAL DISPLAY

From speed, rpm, engine temperature, to fuel level, 4WD status and the time of day, one display tells you everything you need to know.



POWER STEERING

Power steering is standard on the XUV 590i, XUV 590i S4, XUV 825i, XUV 855D and XUV 855D S4.



FULLY INDEPENDENT SUSPENSION

The suspension adjusts to suit your payload and the front/rear travel sets new standards in comfort. A sway bar on the rear axle reduces body roll in extreme conditions.



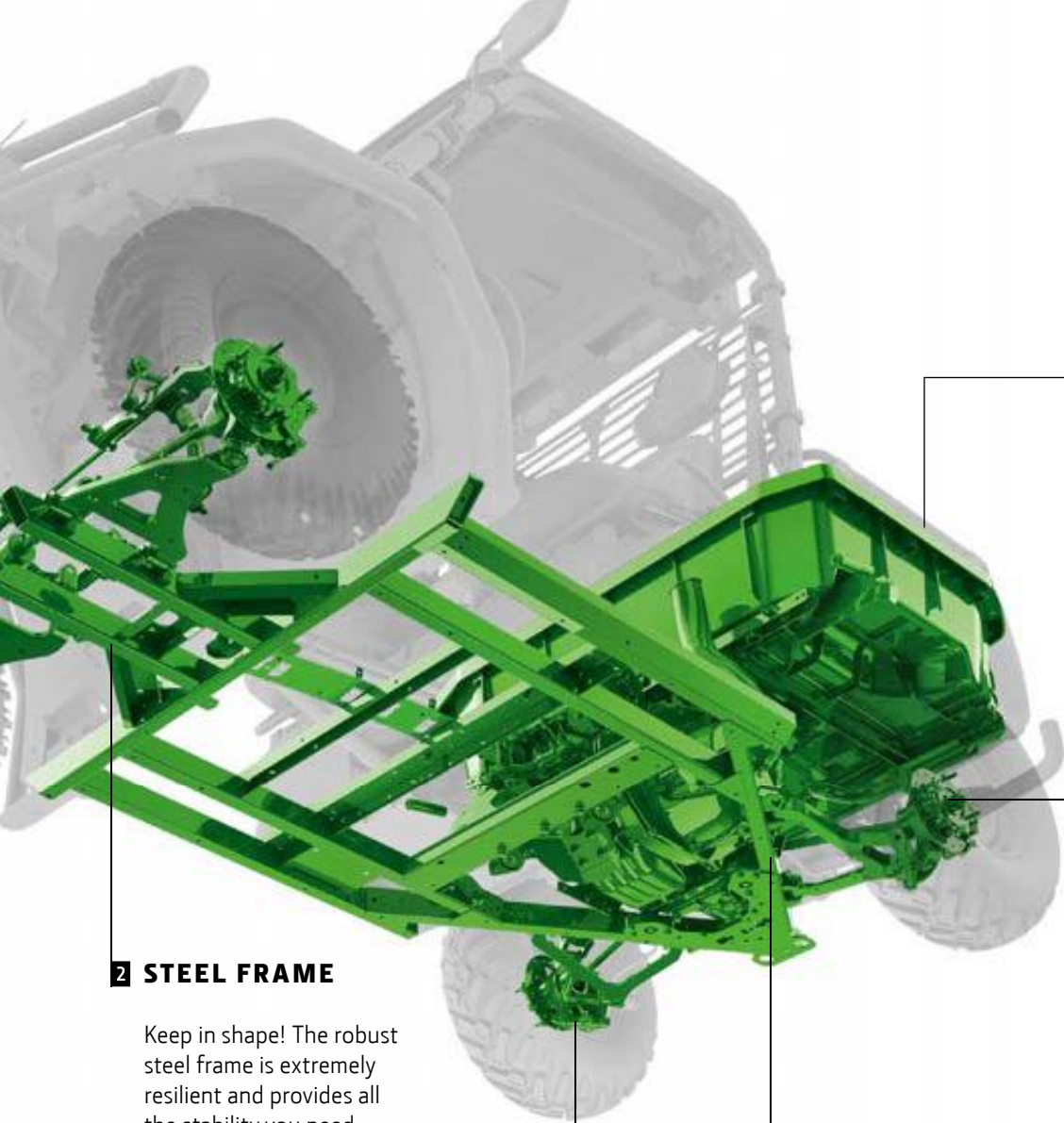

2 STEEL FRAME

Keep in shape! The robust steel frame is extremely resilient and provides all the stability you need.

5 DELUXE CARGO BOX

The Deluxe Cargo Box keeps your load safe and secure, even when the going gets rough.

6 AUTOMOTIVE-STYLE BRAKING SYSTEM

Large, twin piston 8.25" hydraulic disc brakes deliver in all conditions.

3

TRUE ON-DEMAND 4WD

For consistent 2WD, set the dash-mounted electronic rocker switch to 'OFF'. For truly outstanding 4WD performance, set it to 'ON'. This locks the front differential automatically whenever the rear wheels slip. Since rear wheel slip does not occur when going downhill or using the engine to brake, the front wheels do not engage in these circumstances.

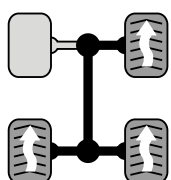

Competition

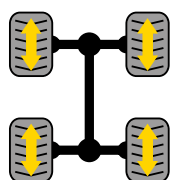

XUV-Series

4



FULLY ENCLOSED CVT TRANSMISSION

Want more speed and comfort combined with even lower consumption? The two-range CVT transmission requires no shifting and delivers superior efficiency from low to high speed.

GATOR XUV 560

EXPERIENCE THE INDEPENDENCE

Only John Deere would call this an entry-level vehicle! Like the rest of the family, our smallest Cross-Over Utility Vehicle is still a heavy-duty workhorse with independent suspension, 4WD and disc brakes all round. Two forward speeds and a 16hp (12 kW) engine gives you versatility to get the job done.





FULLY INDEPENDENT SUSPENSION

Sets the standard for comfort and provides superior terrain capability while maintaining traction through all conditions.

ACCELERATION AND BRAKING CAPACITY

The powerful V-twin engine allows you to accelerate briskly and work more efficiently, whilst the four-wheel hydraulic disc brakes give optimum braking power at all times.



XUV 560

Petrol Engine
Displacement: 570 cc
Speed: 45 km/h
4-Wheel Drive
Fully Independent Suspension
Towing Capacity: 499 kg
Cargo Capacity: 181 kg

- Power and Acceleration
- Superior Terrain Capability
- Road Homologation (Optional)*

*Homologation type may vary by country. Please refer to your dealer.

OPERATOR COMFORT

The automotive-style dashboard, foot pedal parking brake and ample storage capacity make the XUV 560 a pleasure to drive.



FULLY ENCLOSED CVT TRANSMISSION

High engine and CVT air intake positions help to keep water and debris out and prevent overheating.



GATOR XUV 590i

EXPERIENCE THE RANGE

Even with a full payload, this mid-range XUV Cross-Over Utility Vehicle combines high transport speeds and power steering, with superb ride comfort and handling. The powerful twin-cylinder engine and four-wheel independent suspension make light work of challenging terrain – and thanks to the generous sized petrol tank, you can work all day without refuelling.





XUV 590i

Petrol Engine
Displacement: 586 cc
Speed: 73 km/h
4-Wheel Drive
Fully Independent Suspension
Power Steering: Standard
Towing Capacity: 499 kg
Cargo Capacity: 181 kg

- Power and Acceleration
- Road Homologation optional*

*Homologation type may vary by country. Please refer to your dealer.

QUALITY RIDE

Enjoy smooth, comfortable handling thanks to power steering, 4WD and fully independent suspension.



STURDY AND SAFE

The heavy-duty suspension, wheels and tyres are built for years of hard work.

POWER TO SPARE

Even on a 20% gradient, the 32hp engine maintains its top speed of 73 km/h.



NEW DIGITAL CLUSTER

See 18 functions at a glance – from speed and rpm to fuel, temp and diagnostics.



GATOR XUV 590i S4

EXPERIENCE THE INDEPENDENCE

Even with 4 people on board, power steering makes the Gator XUV 590i S4 effortless to drive. The rear bench folds down in seconds to accept longer items or more equipment.





CARGO BOX & MORE CARRYING CAPACITY

The 181 kg dumping cargo box has 20 tie-down points, plus a single handed tailgate latch for easy loading and unloading. For longer items such as pipes or ladders, just fold down the rear bench seat.



NEW

DIGITAL DASH

Read 18 functions at a glance on the brightly-lit new digital display

XUV 590i S4

Petrol Engine
Displacement: 586 cc
Speed: 73 km/h
4-Wheel Drive
Fully Independent Suspension
Power Steering: Standard
Towing Capacity: 499 kg
Cargo Capacity: 181 kg

- Power and Acceleration
- Road Homologation (Optional)*

*Homologation type may vary by country. Please refer to your dealer.



SUSPENSION

Drive with confidence thanks to power steering, true 4WD and fully-independent suspension.

GATOR XUV 855D

EXPERIENCE THE SATISFACTION

When you work hard all day, you need a vehicle that can keep up. With the XUV 855D Utility Vehicle, the moment you climb aboard and turn the key, you know you have found your perfect match.

Tough going and heavy loads? The 854 cc diesel engine has power to spare. Tricky terrain and gradients? Take them in your stride with 4-wheel drive, fully independent suspension and power steering. In fact, the only hard bit is deciding which seats, colour, tyres and attachment options you prefer.





XUV 855D

Diesel Engine
Displacement: 854 cc
Speed: 51 km/h
4-Wheel Drive
Fully Independent Suspension
Power Steering: Standard
Towing Capacity: 680 kg
Cargo Capacity: 454 kg

- Power and Acceleration
- Superior Terrain Capability
- Road Homologation (Optional)*

*Homologation type may vary by country. Please refer to your dealer.

WORKS AS HARD AS YOU DO

With its rugged design and 635 kg total payload, the XUV 855D earns its keep all year round.



STOP AT NOTHING

Power through difficult terrain with confidence, thanks to true on-demand 4-wheel drive.



QUALITY TIME

Arrive with a smile! On-road performance is so good, you'll wish the journey was longer.

CHOOSE YOUR COLOUR

This Gator Utility Vehicle is also setting new standards in design. Whether in classic green and yellow or refined black and olive, it's your choice!



GATOR XUV 855D S4

EXPERIENCE THE FLEXIBILITY

For jobs that demand more manpower, the XUV 855D S4 Cross-Over Vehicle is the ideal choice. It seats four people in comfort with room for all your tools and equipment. Even when you're fully loaded, the power and acceleration are impressive by any standards.

PLENTY OF SPACE FOR FOUR

Four seats. True, on demand 4-wheel drive and fully independent suspension for a smooth, comfortable ride.





XUV 855D S4

Diesel Engine
Displacement: 854 cc
Speed: 51 km/h
4-Wheel Drive
Fully Independent Suspension
Power Steering: Standard
Towing Capacity: 680 kg
Cargo Capacity: 454 kg

CONVERTIBLE REAR BENCH

The rear bench folds down in seconds when you need to carry long items or store your things.

- Power and Acceleration
- Superior Terrain Capability
- Road Homologation (Optional)*

*Homologation type may vary by country. Please refer to your dealer.



A RIDE TO REMEMBER

With a powerful diesel engine, hydraulic disc brakes and power steering, this 4-seater is surprisingly nimble and quick.



GATOR XUV 825i

EXPERIENCE THE POWER

A responsive 812 cc petrol engine for up to 71 km/h. Serious hauling capacity in any terrain. On-demand true 4WD, fully independent suspension and power steering to keep you in command at all times. Whatever the challenge, the XUV 825i Gator Utility Vehicle is ready to take it on.





**POWERED BY
ADRENALINE**

71 km/h top speed and hydraulic disc brakes for fast, safe transport.

XUV 825i

Petrol Engine
Displacement: 812 cc
Speed: 71 km/h
4-Wheel Drive
Fully Independent Suspension
Power Steering: Standard
Towing Capacity: 680 kg
Cargo Capacity: 454 kg

- Superior terrain capability, power and acceleration
- Road Homologation (Optional)*

*Homologation type may vary by country. Please refer to your dealer.



**ACCESS ALL
AREAS**

Overcome all obstacles with true on-demand 4-wheel drive and high ground clearance.



SHORT CUT? WHY NOT?

Standard power steering for exceptional comfort and control. Power through difficult terrain with confidence, thanks to true on-demand 4-wheel drive.

**HAULING
POWER**

Haul even heavy, bulky loads in the deluxe cargo box with ease.



GATOR ATTACHMENTS

EXPERIENCE EVEN MORE

Get even more out of your GATOR Utility Vehicle with our extensive range of top-quality professional attachments.



T-SERIES

ATTACHMENTS



PROTECTION

1 Front bumper

Strong, front mounted, newly designed bumper with brush guard creates a modern and rugged appearance for all Gator T-Series models.

2 Cargo Box Fender Guard

Easily-installed heavy-duty guard protects cargo box and won't interfere with the tipping operation – with either gas-assisted tipping or power lift option (TX 4x2, TE 4x2).

3 Fender Guards

Durable tubing provides additional protection for the front grille, lights and fenders.

4 Heavy Duty Brush Guard

Comprised of strong tubular steel, the heavy-duty bumper and brushguard protects the unit from front impacts and adds increased protection to the grille and headlights.

5 Front Hood Rack

This generously sized rack will carry up to a 45 kg payload. Tilts forward, in conjunction with the brush guard, for full access to under-hood storage and service points.

Rear Bumper

The rear bumper offers stylish, heavy duty rear protection to the vehicle.

BLADES

6 72 Front Blade (1.83 m)

- Snow removal/light material blading
- 3-position manual angling
- Electro-hydraulic lift system
- Quick attach system
- Two adjustable skid shoes
- Replaceable cutting edge

72 V-Front Blade (1.83 m)

- Snow removal/light material blading
- 3-position manual angling
- Electro-hydraulic lift system
- Quick attach system
- Two adjustable skid shoes
- Replaceable cutting edge



CABS / CANOPIES / OPS

1 Windscreen

Easy to attach, height-adjustable tinted acrylic windscreen to protect the operator from dust and wind.

2 T-Series ROPS

Add a spacious ROPS (Roll Over Protection Structure) - certified to your GATOR T-Series UV for year-round protection. Optional front windscreen, glass doors and glass rear window available.

OTHER ACCESSORIES

3 Floor Mat

Washable mat protects the floor and minimises dust, debris and noise in the operator station.

TYRES AND HITCH

4 Turf

- Gentle to the turf
- Very good traction on damp surfaces
- High level of comfort
- Low wear on hard surfaces

5 Cayman AT (All Terrain)

- Universal all-round tyres for on and off-road use
- Good traction off-road
- Low ground pressure

6 Cayman KT (Knobby)

- Universal all-round tyres preferably for off-road use
- Good traction off-road
- Low ground pressure

7 Cayman XT (Extreme Terrain)

- Outstanding traction off-road
- Puncture resistant
- Can also be used on-road

8 Drawbar Hitch

Can be mounted in the standard rear receiver hitch or the optional front receiver hitch for towing trailers.



CARGO BOX

9 Cargo Box Powerlift

Easily lower and raise the cargo box from the seat with the dash mounted switch. Electro-mechanically activated, rated for full box capacity.

10 Cargo Box Side Extension

Cargo Box Side Extensions let you carry twice the amount of light materials such as clippings and mulch. Tailgate pivots at the top (similar to a dump truck) for ease of unloading loose material (TX, TX-Turf, TE, TH).

11 Cargo Box Divider

The Deluxe cargo box can be equipped with optional dividers, that can be positioned at the front or rear and released quickly without any tools.

12 Cargo Box Tool Rack

The side tool rack enables you to maximise the use of the cargo box by carrying long-handled tools. The holders are adjustable, allowing you to carry a wide variety of items in the racks.

SEATS

Ride in style and comfort with our high back or bucket seats. The choice is yours!

Safety

Your safety is our top priority. That’s why every Gator model has comfortable automotive style 3-point seat belts as standard.

13 High-Back Bucket Seats

HOMOLOGATION

Road Homologation

Equipped with the road homologation kit, your Gator utility vehicle can be used in traffic on public roads. Please see the product specifications for details.

LIGHTS

14 Brake/Tail Light Kit

Make your Gator more visible in all conditions by adding the brake and tail light kit.

Deluxe Light Kit

The deluxe light kit includes brake lights, tail lights, turn signals and four-way indicators.

XUV 560 & XUV 590i

ATTACHMENTS



PROTECTION

1 Heavy Duty Brush Guard

Strong bumper-mounted heavy duty brush guard provides a modern and rugged appearance.

2 Roof & Rear Protection Screen

Add more protection from the elements, rear protection screen includes headrests.

Cargo Box Fender Guard

The cargo box fender guard offers enhanced styling in addition to heavy duty protection to the side of the cargo box.

3 Fender Guards

Heavy duty fender guards not only prevent damage from side impact but also create a modern and rugged appearance.

4 Rear Bumper

Protects cargo box and tailgate.

5 Front Hood Rack

Generously sized rack (122 cm long, 34 cm wide by 9 cm deep) will carry up to 45 kg of gear.



CABS / CANOPIES / OPS

6 Deflector Plate

The polyethylene deflector plate slides over obstacles easily while protecting your frame and power train from dirt, debris and damage.

BLADES

7 66 Front Blade (1.68 m)

- Snow removal/light material blading
- 5-position manual angling
- Winch operated (requires additional attachments)
- Two adjustable skid shoes
- Replaceable cutting edge

8 Windscreens

Half, full (shown) and full glass

9 Nets

The nets offer increased safety and protection. (Standard on all XUV and HPX GATOR Utility Vehicles)

10 Rear Wind Screen

Add more protection from the elements with a hard plastic screen.

11 Hard Plastic Door

These doors are ideal for all season weather protection. Not for road homologation.



OTHER ACCESSORIES

1 Speedometer

Electronic speedometer and voltmeter analogue gauges integrated in the instrument panel. Good for precision tasks (XUV 560).

2 Sport Steering Wheel

Colour accents and a comfortable feel make this a must-have!

3 Winch

- For loads up to 1587 kg
- Designed for moving logs, pulling out bushes with control or tension fences
- Increased efficiency and improved load distribution due to quiet, three-stage planetary gear design
- Mounts front and rear

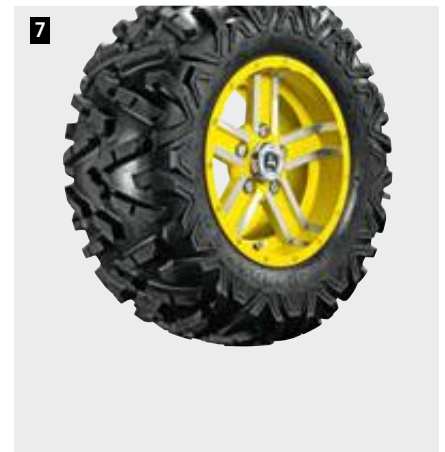
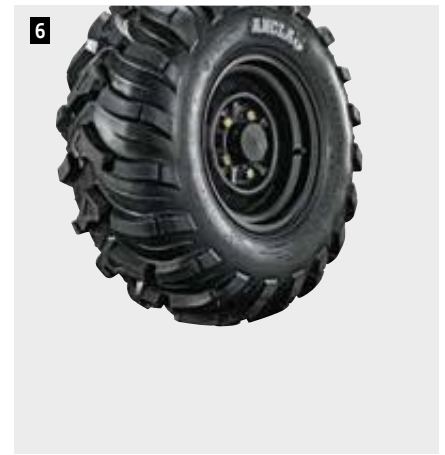

TYRES

4 Directional Turf

- Minimal impact on terrain
- Longevity on hard surfaces
- 4-ply rating for excellent puncture resistance

5 HPAP (High Performance All Purpose)

- Optimum traction
- Minimum impact on terrain (XUV 560, XUV 590i, HPX)

6 Ancla M-T (Extreme Terrain)

- Aggressive off-road tread pattern
- Superior traction in mud, without sacrificing ride comfort
- 4-ply rating for excellent puncture resistance

7 Maxxis Big Horn 2.0 Radials

- Radial tyre construction provides better shock absorption
- Alloy rims for maximum performance, ease of cleaning and look
- Non-directional tread pattern provides predictable cornering and claws up roots and stones
- 6-ply rating for maximum puncture resistance and lifetime



SEATS

Ride in style and comfort with our high back or bucket seats. The choice is yours!

Safety

Your safety is our top priority. That's why every Gator has comfortable, automotive style 3-point seat belts as standard.

8 High-Back Bucket Seats

CARGO BOX

9 Cargo Box Powerlift

Easily lower and raise the cargo box from the seat with the dash mounted switch. Electro-mechanically activated, rated for full box capacity.

10 Cargo Box Side Extensions

Extend your cargo space with these Quick-Clamp extensions.

HOMOLOGATION

11 Road Homologation

Equipped with the road homologation kit, your Gator utility vehicle can be used in traffic on public roads. Please see the product specifications for details.

LIGHTS

12 Deluxe Light Kit

The deluxe light kit includes brake lights, tail lights, turn signals and four-way flashers.

13 Hella Performance Spotlights

Two 55 watt lights mounted on the heavy duty brush guard to increase the illuminated area.

LED Work Lights

The LED's can be mounted on the brush guard, the roof front and the rear.

XUV 855D, XUV 825i & HPX

ATTACHMENTS



1



3



2



4



5

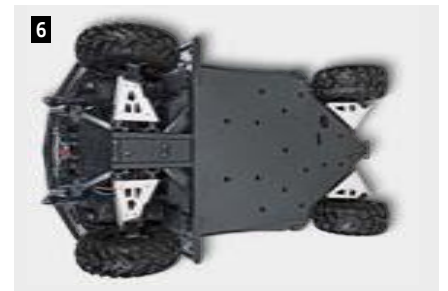

6

PROTECTION

1 Heavy Duty Front Brush Guard

Strong bumper-mounted heavy duty brush guard provides a modern and rugged appearance.

2 Rear Bumper

The rear bumper offers stylish, heavy duty rear protection to the vehicle.

3 Cargo Box Fender Guard

The cargo box fender guard offers enhanced styling in addition to heavy duty protection to the side of the cargo box.

4 Front Fender Guards

Heavy duty fender guards not only prevent damage from side impact but also create a modern and rugged appearance.

5 Front Bonnet Rack

Expand the work capabilities of your Gator Utility Vehicle with the addition of the front bonnet rack. The rack easily mounts to the required front brush guard.

6 Deflector plate

The deflector plate sits next to the existing powertrain deflector to help avoid mud and dirt build up. Please note, this is not a full skid plate.



BLADES

7 72 Front Blade (1.83 m)

- Snow removal/light material blading
- 3-position manual angling
- Electro-hydraulic lift system
- Quick attach system
- Two adjustable skid shoes
- Replaceable cutting edge

8 72 V-Front Blade (1.83 m)

- Snow removal/light material blading
- 3-position manual angling
- Electro-hydraulic lift system
- Quick attach system
- Two adjustable skid shoes
- Replaceable cutting edge

SEATS

Ride in style and comfort with our high back, bench or bucket seats. The choice is yours!

Safety

Your safety is our top priority. That's why every Gator Utility Vehicle has comfortable automotive style 3-point seat belts as standard.

9 Sport Seat

10 High-Back Bucket Seats

11 Bench Seat

HOMOLOGATION

12 Road Homologation

Equipped with the road homologation kit, your Gator utility vehicle can be used in traffic on public roads. Please see the product specifications for details.

LIGHTS

13 Deluxe Light Kit

The deluxe light kit includes brake lights, tail lights, turn signals and four-way flashers.

14 Hella Performance Spotlights

Two 55 watt lights mounted on the heavy duty brush guard to increase the illuminated area.



CARGO BOX

1 Cargo Box Powerlift

Easily lower and raise the cargo box from the seat with the dash mounted switch. Electro-mechanically activated, rated for full box capacity.

2 Cargo Box Tool Rack

The side tool rack enables you to maximise the use of the cargo box by carrying long-handled tools. The holders are adjustable, allowing you to carry a wide array of items in the racks.

3 Cargo Box Side Extension

Cargo Box Side Extensions let you carry twice the amount of light materials such as clippings and mulch. Tailgate pivots at the top (similar to a dump truck) for ease of unloading loose material. (XUV 825i, 855D, XUV 855D S4) Mesh style side extensions available for HPX.

4 Cargo Box Divider

The Deluxe cargo box can be equipped with optional dividers, that can be positioned at the front or rear and released quickly without any tools.

OTHER ACCESSORIES

Floor Mat

Washable mat protects the floor and minimises dust, debris and noise in the operator station.

5 Cab Heater

Stay warm all year-round. High-output two-speed heater also defrosts windshield. Requires appropriate Heater Fitting Kit.

6 Winch

- For loads up to 1134 kg
- Designed for moving logs, pulling out bushes with control or tension fences
- Increased efficiency and improved load distribution due to quiet, three-stage planetary gear design
- Mounts front and rear

CABS / CANOPIES / OPS

7 Deluxe Canopy

Certified to the Society of Automotive Engineers (SAE) requirements to provide roll-over protection. Includes 3-point seat belts and can be enhanced to a full comfort cab.

8 Windshield

Full glass windshield

9 Plastic Half Door

The robust, lightweight plastic doors provide extra safety for occupants and keep rain and mud out (XUV 855D S4).



10



11



12



13



14



15

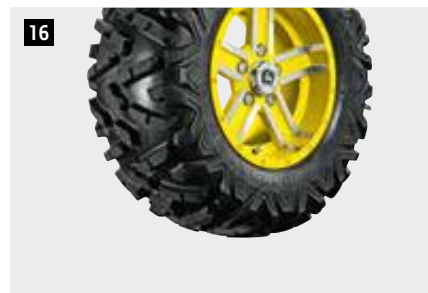

16



17



18

TYRES AND HITCH

10 Nets

The nets offer increased safety and protection. (Standard on all XUV and HPX Gator Utility Vehicles)

Rear Screen

Provides additional protection to the rear.

11 Poly Doors for Deluxe Cab

Comes equipped with manual roll down window and numerous storage compartments.

12 Draw Bar / Ball Hitches

Can be mounted in the standard rear receiver hitch or the optional front receiver hitch for towing trailers.

13 Turf

- Gentle to the turf
- Very good traction on damp surfaces
- High level of comfort
- Low wear on hard surfaces (HPX)

14 Terra-Hawk AT (All Terrain)

- Universal all-round tyres for on and off-road use
- Good traction off-road
- Low ground pressure (XUV 855D, XUV825i)

15 NEW steel rims for Maxxis tyres

- Larger 14" diameter improves ride and performance
- Bigger holes for easier cleaning
- Fits GATOR XUV855D/825i S2 and S4 Models (MY16)

16 Maxxis Big Horn 2.0 Radials

- Radial tyre construction provides better shock absorption
- Alloy rims for maximum performance, ease of cleaning and look
- Non-directional tread pattern provides predictable cornering and claws up roots and rocks
- 6-ply rating for maximum puncture resistance and lifetime (Fits XUV855D / 825i S2 and S4 Gators)

17 Ancla M-T (Extreme Terrain)

- Aggressive off-road tread pattern
- Superior traction in mud, without sacrificing ride comfort
- 4-ply rating for excellent puncture resistance (Fits XUV855D / 825i S2 and S4 Gators)



18 Camso Tracks

- Maximum flotation in all terrain
 - Up to 75% lower ground pressure
 - Fitted in under 2 hours
- Contact your dealer for details!

	TS	TX	TX Turf	TE	TH	HPX
Cargo Box						
Cargo Box Lift Manual	■	■	■	■	■	■
Cargo Box Power Lift	□	□	□	□	□	□
Cargo Box Side Wall Extension		□	□	□	□	
Cargo Box Divider Kit		□	□	□	□	
Cargo Box Tool Rack		□	□	□	□	
Cargo Box Fender Guard		□	□	□		
Cargo Box Bedliner	□					□
Cargo Box Rails						
Cargo Box Spray in Bedliner		■	■	■	■	
Cargo Box Mat		□	□	□	□	
Cargo Box Rubber Mat	□					□
Cargo Box Side Storage Box	□	□	□			□
Hitch						
Rear Hitch	□	□	□	□	□	□
Ball Hitch	□	□	□	□	□	□
Rear Receiver Hitch	□	□	□	□	□	□
Drawbar	□	□	□	□	□	□
Front Receiver Hitch	□	□		□		□
Blades						
66 Blade (1.68 m)						
72 Blade (1.83 m)	□	□	□	□	□	□
72 V-Blade (1.83 m)	□	□	□	□	□	□
Tyres						
Cayman LS (Lawn & Street)						
Turf	□	□	□	□	□	□
Directional Turf						
Cayman AT (All Terrain)	□	□			□	
Cayman KT (Knobby)	□				□	
Cayman XT (Extrem Terrain)		□				
HPAP (High Performance All Purpose)						□
HPAT (Aggressive Tread)						□
Terra-Hawk AT (All Terrain)						
Ancla M-T (Extrem Terrain)						
Maxxis Big Horn 2.0 Radials						
Steel 14 rim Maxxis Big Horn Tyre						
Camso Tracks						
Other accessories						
Winch	□	□	□	□	□	□
Back-Up Alarm	□	□	□	■	□	□
Bucket Holder		□	□	□	□	
High Capacity Alternator Kit (55 Amp)	□	□			□	
Horn Kit	□	□	□	□	□	■
Speedometer						
Seat Cover	□	□	□	□	□	□

XUV 560	XUV 590i	XUV 590i S4	XUV 855D	XUV 855D S4	XUV 825i
■	■	■	■	■	■
□	□	□	□	□	□
□	□	□	□	□	□
			□	□	□
			□	□	□
□	□	□	□	□	□
□	□	□			
□	□	□			
■	■	■	■	■	■
□	□		□	□	□
□	□	□			
□	□		□	□	□
			■		
□	□	□			
□	□	□			
□	□		□	□	□
□	□		□	□	□
			□	□	□
			□	□	□
□	□	□	□	□	□
□	□	□	□	□	□
□	□	□	□	□	□
□	■***	■***	■	■	■
■	■	■	□	□	□
□					
□	□	□			

■ Standard □ Optional * Mirrors are optional on the Standard OPS ** Homologation type may vary by country. Please refer to your dealer. *** XUV590i has a 65 Amp alternator

T-SERIES			
Work Series			
	TS	TX /TX Turf	TE
			
Engine			
Type	401 cc, 1-Cylinder, 4-Cycle Petrol	675 cc / 401 cc, 2-Cylinder / 1-Cylinder, 4-Cycle Petrol	48 VDC Separately Exited, Electric Petrol
Power kW (hp) @ min ⁻¹	7.1 (9.7) @ 3300 98 / 67 / EC	12.5 (16.8) @ 3200 / 8 (10.9) @ 3250 98 / 67 / EC	48 V with 8 Trojan T-145 Batteries
Cooling System	Air	Air	NA
Fuel Tank, litres	18.9	18.9	NA
Power Steering	NA	NA	NA
4-Wheel Drive	No	No	No
Drive System			
Type	CVT (Continuously Variable Transmission)	CVT (Continuously Variable Transmission)	NA
Ground Speed, km/h*	0–32 Forward	0–32 Forward / 0–25 Forward	0–24 Forward
Differential Lock	Standard, Hand-Operated	Standard, Hand-Operated	
Brakes	Wet Disc in Transaxle	All-Wheel Hydraulic Disc	Dual Rear Wheel Mechanical Drum
Suspension, Front	Independent Spring-Over-Shock, Single A-Arm	Independent Spring-Over-Shock, Single A-Arm	Independent Spring-Over-Shock, Single A-Arm
Suspension, Rear	Two High-Flotation Tyres, Low Pressure Tyres (Solid Axle)	Semi-Independent Coil-Over-Shock	Two High-Flotation Tyres, Low Pressure Tyres (Solid Axle)
Suspension Travel, mm	127 Front	127 Front & 76 Rear	127 Front
Dimensions			
Dimensions (W x L x H), mm	1525 x 2746 x 1108	1525 x 2847 x 1108 / 1525 x 2847 x 1209	1525 x 2728 x 1130
Weight (Including Fluids), kg	415	508 / 501	667 w / Batteries
Towing Capacity, kg	408	454	273
Payload Capacity, kg	408	454	409
Ground Clearance	Under Transaxle: 152 Under Foot Platform: 250	Under Transaxle: 145 Under Foot Platform: 270	Under Foot Platform: 185
Deluxe Cargo Box			
Type / Material	16 Gauge Steel	Deluxe (Polypropylene Side Panels and Tailgate; Steel Floor and Load Guard)	Deluxe (Polypropylene Side Panels and Tailgate; Steel Floor and Load Guard)
Dimensions (L x W x D), mm	1003 x 1245 x 229	1143 x 1320 x 305	1143 x 1320 x 305
Volume, litres	290	460	460
Capacity, kg	227	272	227
Tyres			
Front	22.5 x 10–8, 4 PR Cayman KT (Knobby) 22.5 x 10–8, 4 PR Cayman Turf 22.5 x 10–8, 4 PR Cayman AT (All Terrain)	22 x 9.5–10, 4 PR Cayman AT (All Terrain – Only Available on TX) 22 x 9.5–10, 4 PR Cayman Turf 22 x 9.5–10, 4 PR Cayman XT (Xtreme Terrain – Only Available on TX)	22x9.5–10, 4 PR Cayman Turf
Rear	25 x 12–9, 4 PR Cayman KT (Knobby) 25 x 12–9, 4 PR Cayman Turf 25 x 13–9, 4 PR Cayman AT (All Terrain)	24 x 10.5–10, 4 PR Cayman AT (All Terrain – Only Available on TX) 24 x 12–10, 4 PR Cayman Turf 24 x 12–10, 4 PR Cayman XT (Xtreme Terrain – Only Available on TX)	24 x 12–10, 4 PR Cayman Turf
Colours	Green & Yellow	Green & Yellow	Green & Yellow
Seating Capacity	2	2	2

*Homologation type and speed may vary by country. Please refer to your dealer.

TH 6x4



854 cc, 3-Cylinder, 4-Cycle, Diesel
13.6 (18.5) @ 3400 ECE-R24
Liquid
18.9
NA
Yes
CVT (Continuously Variable Transmission)
0–32 Forward
Standard, Hand-Operated
Wet Disc in Transaxle
Independent Spring-Over-Shock, Single A-Arm
Two High-Flotation Tyres, Low Pressure Tyres (Solid Axle)
127 Front
1525 x 2754 x 1108
630
726
726
Under Transaxle: 165 Under Foot Platform: 216
Deluxe (Polypropylene Side Panels and Tailgate; Steel Floor and Load Guard)
1143 x 1320 x 305
460
544
22.5 x 10–8, 4 PR Cayman KT (Knobby) 22.5 x 10–8, 4 PR Cayman Turf 22.5 x 10–8, 4 PR Cayman AT (All Terrain)
25 x 12–9, 4 PR Cayman KT (Knobby) 25 x 12–9, 4 PR Cayman Turf 25 x 13–9, 4 PR Cayman AT (All Terrain)
Green & Yellow
2

HPX

Work Series

HPX



854 cc, 3-Cylinder, 4-Cycle, Diesel
13.6 (18.5) @ 3400 ECE-R24
Liquid
20.1
NA
Yes
2-speed CVT (Continuously Variable Transmission)
0–40 Forward
Auto-Locking (Front) / Positive Locking, Mechanically Actuated-Hand-Operated (Rear)
Front / Rear Hydraulic Disc
Independent with McPherson Strut
Coil-Over-Shock
131 Front & 90 Rear
1506 x 2870 x 1867
693
590
635
Under Transaxle: 152 Under Foot Platform: 305
Steel
1116 x 1244 x 229
320
454
24 x 9.5–10, 4 PR High Performance All Purpose (HPAP) 24 x 9.5–10, 4 PR High Performance All Terrain (HPAT) 24 x 9.5–10, 4 PR Turf
24 x 10.5–10, 4 PR High Performance All Purpose (HPAP) 24 x 12–10, 4 PR High Performance All Terrain (HPAT) 24 x 12–10, 4 PR Turf
Green & Yellow
2

PROGATOR

Work Series

ProGator



1115 cc, 3-Cylinder, Diesel
16.5 (22.1) @ 3200
Liquid
30.3
Yes
Yes, Optional
5-speed Synchromesh with Five Forward Gears and One Reverse Gear
0–31 Forward
Standard, Hand-Operated
Front / Rear Hydraulic Disc
Dual Leaf Springs and Shocks
Dual Leaf Springs and Shocks
–
1586 x 3285 x 1936
856 (Base Maschine, No Driver, No Passenger, No Loaded Attachment) 680
1535 (Payload Capacity for 4-Wheel Drive Version with Heavy Duty Suspension)
Under Transaxle: 168
Steel
1600 x 1283 x 267
550
907
23 x 10.50–12, 4 PR Industrial Trax 23 x 10.50–12, 4 PR Smooth Tyres
26 x 12.00–12, 4 PR MultiTrac C/S 26 x 14.00–12, 4 PR MultiTrac C/S 26 x 14.00–12, 4 PR Smooth Tyres 26 x 14.00–12, 4 PR Fairway Tyres
Green & Yellow
2

XUV-SERIES

Cross-Over Series

XUV 560**XUV 590i****XUV 590i S4**

Engine			
Type	570 cc, 4 cycle petrol, dynamically turned carb	586 cc, 4 cycle petrol, electronic fuel injection (EFI)	586 cc, 4 cycle petrol, electronic fuel injection (EFI)
Power kW (hp) @ min ⁻¹	12.1 (16) @ 3600 97 / 68 / EC	23.9 (32) @ 5600 97 / 68 / EC	23.9 (32) @ 5600 97 / 68 / EC
Cooling System	Air	Liquid	Liquid
Fuel Tank, litres	18.5	28	28
Power Steering	No	Standard	Standard
4-Wheel Drive	Yes	Yes	Yes
Drive System			
Type	2-speed CVT (Continuously Variable Transmission) with Clutch Enclosure	2-speed CVT (Continuously Variable Transmission) with Clutch Enclosure	2-speed CVT (Continuously Variable Transmission) with Clutch Enclosure
Ground Speed, km/h*	0–45 Forward	0–73 Forward	0–73 Forward
Differential Lock	Limited Slip (Front) / Positive Locking, Mechanically Actuated – Hand-Operated (Rear)	Limited Slip (Front) / Positive Locking, Mechanically Actuated – Hand-Operated (Rear)	Limited Slip (Front) / Positive Locking, Mechanically Actuated – Hand-Operated (Rear)
Brakes	Front/Rear Hydraulic Disc w/twin piston calipers and stainless steel rotors	Front/Rear Hydraulic Disc w/twin piston calipers and stainless steel rotors	Front/Rear Hydraulic Disc w/twin piston calipers and stainless steel rotors
Suspension, Front	Independent; double A-arm w/ adjustable coil over shock	Independent; double A-arm w/ adjustable coil over shock	Independent; double A-arm w/ adjustable coil over shock
Suspension, Rear	Independent; lower H-arm and upper camber link w/ adjustable coil cover shocks	Independent; lower H-arm and upper camber link w/ adjustable coil cover shocks	Independent; lower H-arm and upper camber link w/ adjustable coil cover shocks
Suspension Travel, mm	203 Front & 203 Rear	203 Front & 203 Rear	203 Front & 203 Rear
Dimensions			
Dimensions (W x L x H), mm	1435 x 2921 x 1867	1435 x 2921 x 1867	1435 x 3658 x 1880
Weight (Including Fluids), kg	576	644	746
Towing Capacity, kg	499	499	499
Payload Capacity, kg	363	363	544
Ground Clearance	Under Transaxle: 267 Under Foot Platform: 267	Under Transaxle: 267 Under Foot Platform: 267	Under Transaxle: 236 Under Foot Platform: 236
Deluxe Cargo Box			
Type / Material	High-Density Polyethylene Copolymer Composite	High-Density Polyethylene Copolymer Composite	High-Density Polyethylene Copolymer Composite
Dimensions (L x W x D), mm	820 x 1209 x 297	820 x 1209 x 297	820 x 1209 x 297
Volume, litres	250	250	250 (up to 370 with Convertible Cargo Rack)
Capacity, kg	181	181	181
Tyres			
Front	25 x 8–12 Ancla MT 26 x 8–14 Maxxis Big Horn 2.0, Radial 25 x 8–12 Terrahawk AT (All Terrain)	25 x 8–12 Ancla MT 26 x 8–14 Maxxis Big Horn 2.0, Radial 25 x 8–12 Terrahawk AT (All Terrain)	25 x 8–12 Ancla MT 26 x 8–14 Maxxis Big Horn 2.0, Radial 25 x 8–12 Terrahawk AT (All Terrain)
Rear	25 x 10–12 Ancla MT 26 x 10–14 Maxxis Big Horn 2.0, Radial 25 x 10–12 Terrahawk AT (All Terrain)	25 x 10–12 Ancla MT 26 x 10–14 Maxxis Big Horn 2.0, Radial 25 x 10–12 Terrahawk AT (All Terrain)	25 x 10–12 Ancla MT 26 x 10–14 Maxxis Big Horn 2.0, Radial 25 x 10–12 Terrahawk AT (All Terrain)
Colours	Green & Yellow	Green & Yellow	Green & Yellow
Seating Capacity	2	2	4

*Homologation type and speed may vary by country. Please refer to your dealer.

XUV 855D**XUV 855D S4****XUV 825i**

854 cc, 3-Cylinder Diesel	854 cc, 3-Cylinder Diesel	812 cc, 3-Cylinder Petrol. Electronic Fuel Injection (EFI)
16.1 (21.9) @ 3400 ECE-R24	16.1 (21.9) @ 3400 ECE-R24	37 (50) @ 6000 J1349
Liquid	Liquid	Liquid
27.6	27.6	27.6
Standard	Standard	Standard
Yes	Yes	Yes
2-speed CVT (Continuously Variable Transmission) with Enclosed Clutch & Engine Braking	2-speed CVT (Continuously Variable Transmission) with Enclosed Clutch & Engine Braking	2-speed CVT (Continuously Variable Transmission) with Enclosed Clutch & Engine Braking
0–51* Forward	0–51* Forward	0–71 Forward
Auto-Locking (Front) / Positive Locking, Mechanically Actuated – Hand-Operated (Rear)	Auto-Locking (Front) / Positive Locking, Mechanically Actuated – Hand-Operated (Rear)	Auto-Locking (Front) / Positive Locking, Mechanically Actuated – Hand-Operated (Rear)
Front / Rear Hydraulic Disc	Front / Rear Hydraulic Disc	Front / Rear Hydraulic Disc
Fully Independent Dual A-Arm with Adjustable Coils	Fully Independent Dual A-Arm with Adjustable Coils	Fully Independent Dual A-Arm with Adjustable Coils
Fully Independent Dual A-Arm with Adjustable Coils & Sway Bar	Fully Independent Dual A-Arm with Adjustable Coils & Sway Bar	Fully Independent Dual A-Arm with Adjustable Coils & Sway Bar
203 Front & 229 Rear	203 Front & 229 Rear	203 Front & 229 Rear
1571 x 3021 x 1903	1571 x 3911 x 1903	1571 x 3021 x 1903
788	946	788
680	680	680
635	635	635
Under Transaxle: 267 Under Foot Platform: 311	Under Transaxle: 267 Under Foot Platform: 311	Under Transaxle: 267 Under Foot Platform: 311
Deluxe (Polypropylene Side Panels and Tailgate; Steel Floor and Load Guard)	Deluxe (Polypropylene Side Panels and Tailgate; Steel Floor and Load Guard)	Deluxe (Polypropylene Side Panels and Tailgate; Steel Floor and Load Guard)
1143 x 1320 x 305	1143 x 1320 x 305	1143 x 1320 x 305
460	460	460
454	454	454
26 x 9.00–12, 4 PR Ancla XT 25 x 9.00–12, 4 PR Terrahawk AT 27 x 9.00–14, 6 PR Big Horn Maxxis XT	25 x 9.00–12, 4 PR Terrahawk AT 27 x 9.00–14, 6 PR Big Horn Maxxis XT	26 x 9.00–12, 4 PR Ancla XT 25 x 9.00–12, 4 PR Terrahawk AT 27 x 9.00–14, 6 PR Big Horn Maxxis XT
26 x 11.00–12, 4 PR Ancla XT 25 x 11.00–12, 4 PR Terrahawk AT 27 x 11.00–14, 6 PR Big Horn Maxxis XT	25 x 11.00–12, 4 PR Terrahawk AT 27 x 11.00–14, 6 PR Big Horn Maxxis XT	26 x 11.00–12, 4 PR Ancla XT 25 x 11.00–12, 4 PR Terrahawk AT 27 x 11.00–14, 6 PR Big Horn Maxxis XT
Green & Yellow, Olive & Black	Olive & Black	Green & Yellow
2	4	2

THE ORIGINALS!

JOHN DEERE FUN FOR THE WHOLE FAMILY

Show off your Deere pride with official John Deere merchandise! From Gator scale models to caps, workwear and accessories, your John Deere dealer has a great selection in store – or shop online at:

JohnDeereShop.com



John Deere Financial – A range of finance options as powerful as our products. Contact your John Deere dealer for a comprehensive range of finance options to suit the specific needs of your business. Not available in all countries please consult your local dealer. This literature has been compiled for worldwide circulation. While general information, pictures and descriptions are provided, some illustrations and text may include finance, credit, insurance, product options and accessories not available in all regions. Please contact your local dealer for details. John Deere reserves the right to change specification and design of products described in this literature without notice. The green and yellow colour scheme, the leaping deer logo and the JOHN DEERE word mark are trademarks of Deere & Company.

JohnDeere.com